

- NOTES:**
1. ALL MATERIALS LISTED ON ALL DRAWINGS REPRESENT INFORMATION AND DIMENSIONS FOR A FULL COURT AREA CONSISTING OF 2 TEAM COURT AREAS.
 2. TEAM COURT AREAS ARE MIRRORED ALONG THE MIDDLE AXIS. DIMENSIONS ARE ALSO MIRRORED.

- LEGEND:**
- DIRECTION OF SPOUT
 - [S] SHORT TREE
 - [T] TALL TREE
 - [Sap.] SAPLING
 - [R] ROCK (SAPLING BASE CAP)

-	-	-	-
0	ISSUED FOR SCOPE DOCUMENT	SM	JUL 31/23
REV:	DESCRIPTION:	BY:	DATE:
REVISIONS			

PROJECT: SCNC QUEBEC CITY 2024 - ROBOTICS	SCNC_RC_2024_1 DRAWING NO.	T2024 PROJECT NO.	07/31/23 DATE.
DRAWING TITLE: OVERALL ROUND ROBIN COURT LAYOUT	AS NOTED SCALE AT A4.	SM DRAWN.	DD CHECKED.
		0 REVISION.	

SKILLS CANADA
 294 Albert Street, Suite 201
 Ottawa, Ontario
 1 (877) 754-5226



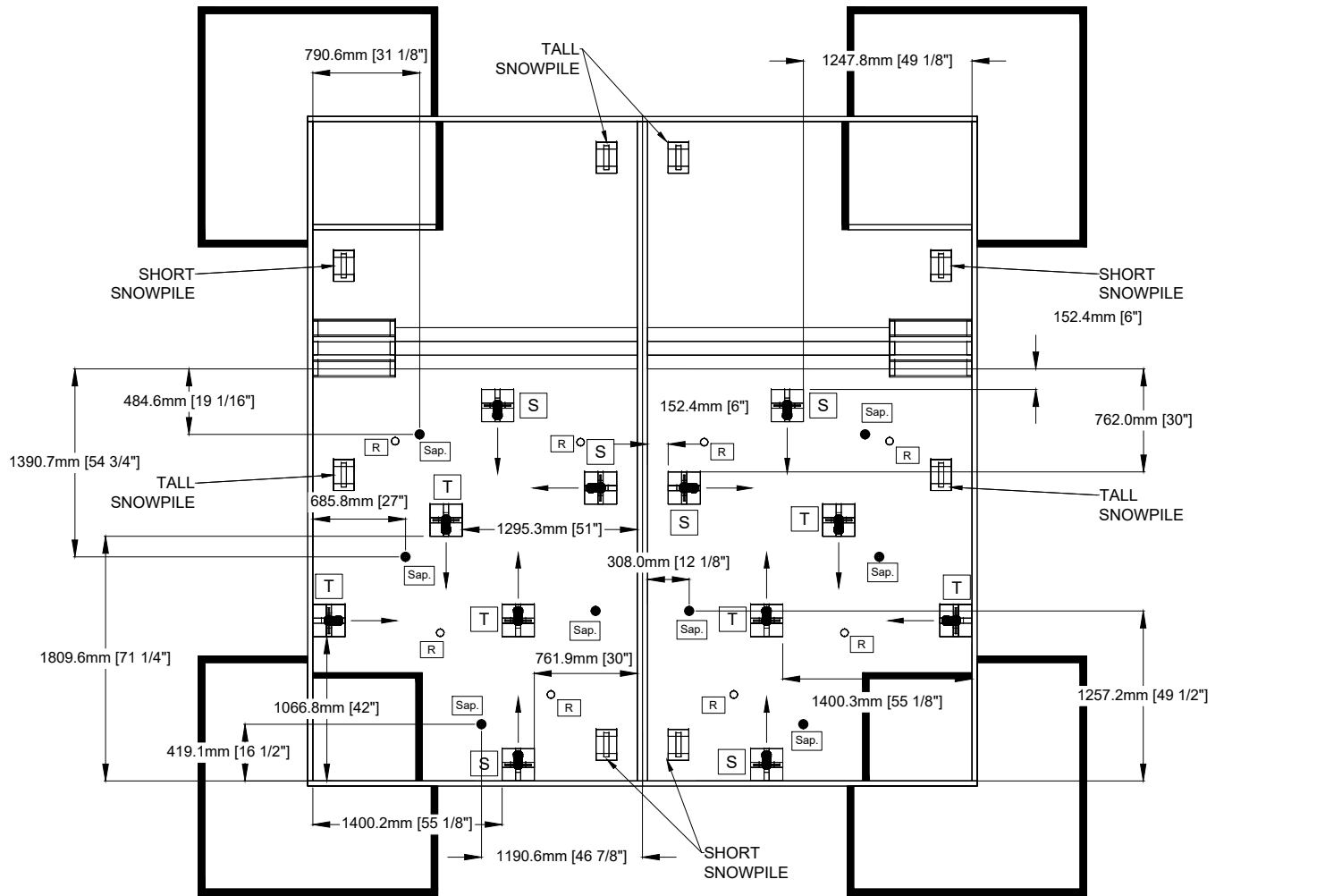

OVERALL COURT AREA
(TOURNAMENT LAYOUT)
SCALE = 1:50 (ON 8.5" x 11" PAPER)

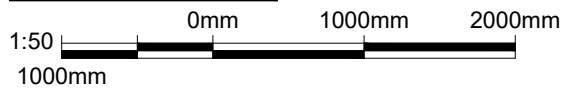

NOTES:

1. ALL MATERIALS LISTED ON ALL DRAWINGS REPRESENT INFORMATION AND DIMENSIONS FOR A FULL COURT AREA CONSISTING OF 2 TEAM COURT AREAS.
2. TEAM COURT AREAS ARE MIRRORED ALONG THE MIDDLE AXIS. DIMENSIONS ARE ALSO MIRRORED.

LEGEND:

- DIRECTION OF SPOUT
- [S] SHORT TREE
- [T] TALL TREE
- [Sap.] SAPLING
- [R] ROCK (SAPLING BASE CAP)

REV:	DESCRIPTION:	BY:	DATE:
-	-	-	-
0	ISSUED FOR SCOPE DOCUMENT	SM	JUL. 31/23

PROJECT: SCNC QUEBEC CITY 2024 - ROBOTICS

SCNC_RC_2024_2
DRAWING NO.

T2024
PROJECT NO.

07/31/23
DATE.

SKILLS CANADA
294 Albert Street, Suite 201
Ottawa, Ontario
1 (877) 754-5226

DRAWING TITLE:
OVERALL TOURNAMENT LAYOUT

AS NOTED
SCALE AT A4.

SM
DRAWN.

DD
CHECKED.

0
REVISION.



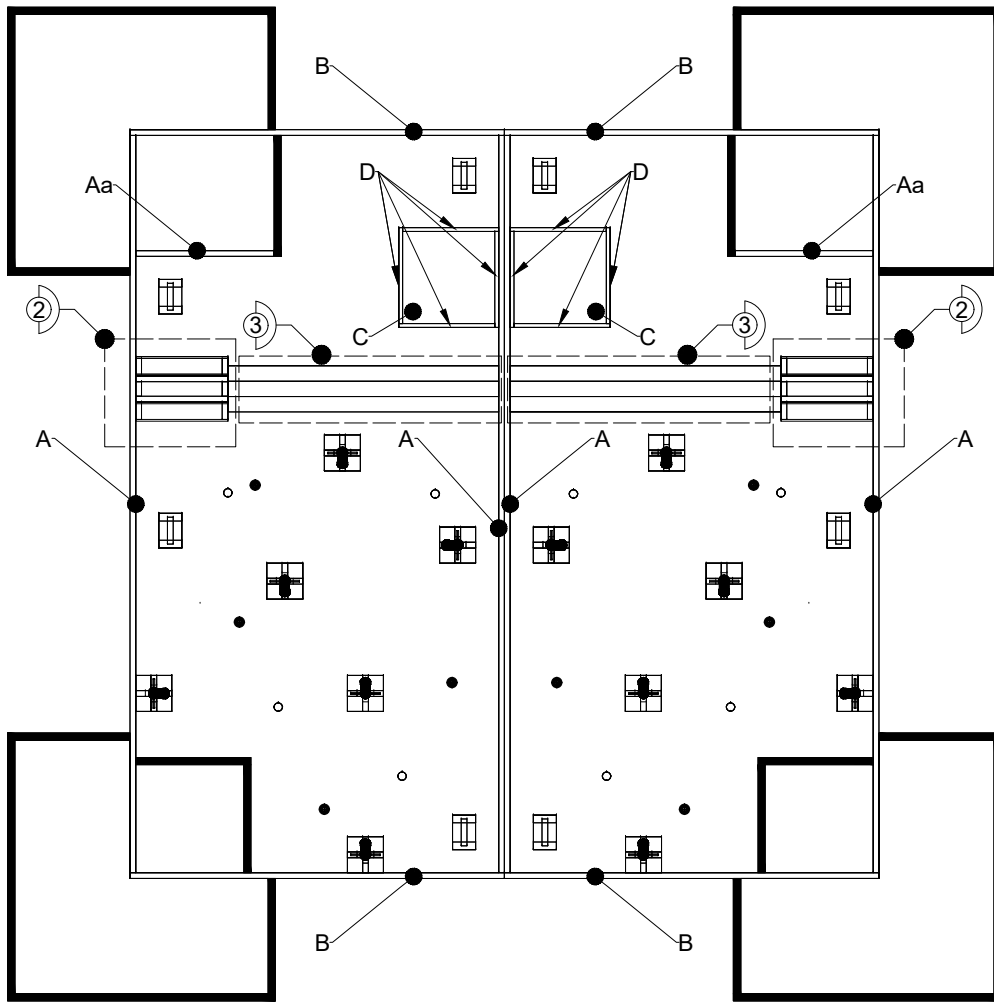

① MAIN STRUCTURAL PIECES LABELLING
 SCALE = 1:50 (ON 8.5" x 11" PAPER)
 0mm 1000mm 2000mm
 1:50
 1000mm

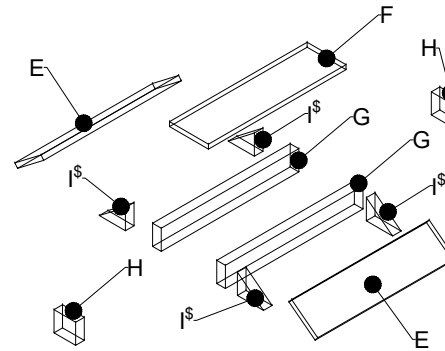

② RAMP ASSEMBLY DETAILS
 SCALE = N/A

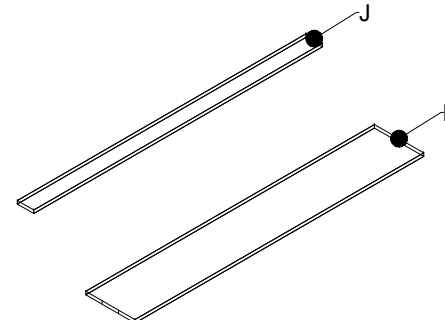

③ RAMP ASSEMBLY DETAILS
 SCALE = N/A

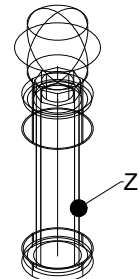

④ SAPLING PART LABELLING
 SCALE = N/A

NOTES:

1. ALL MATERIALS LISTED ON ALL DRAWINGS REPRESENT INFORMATION AND DIMENSIONS FOR A FULL COURT AREA CONSISTING OF 2 TEAM COURT AREAS.
2. TEAM COURT AREAS ARE MIRRORED ALONG THE MIDDLE AXIS. DIMENSIONS ARE ALSO MIRRORED.

KEYNOTES:

\$ NOTED PIECES TO BE ANGLE CUT. SEE DIMENSIONS SHEET FOR DETAILS

-	-	-	-
-	-	-	-
0	ISSUED FOR SCOPE DOCUMENT	SM	JUL 31/23
REV:	DESCRIPTION:	BY:	DATE:

REVISIONS

PROJECT: SCNC QUEBEC CITY 2024 - ROBOTICS

SCNC_RC_2024_3
 DRAWING NO.

T2024
 PROJECT NO. 07/31/23
 DATE.

DRAWING TITLE: PART LABELLING (1 OF 2)

AS NOTED
 SCALE AT A4.

SM
 DRAWN.

DD
 CHECKED.

0
 REVISION.



SKILLS CANADA
 294 Albert Street, Suite 201
 Ottawa, Ontario
 1 (877) 754-5226

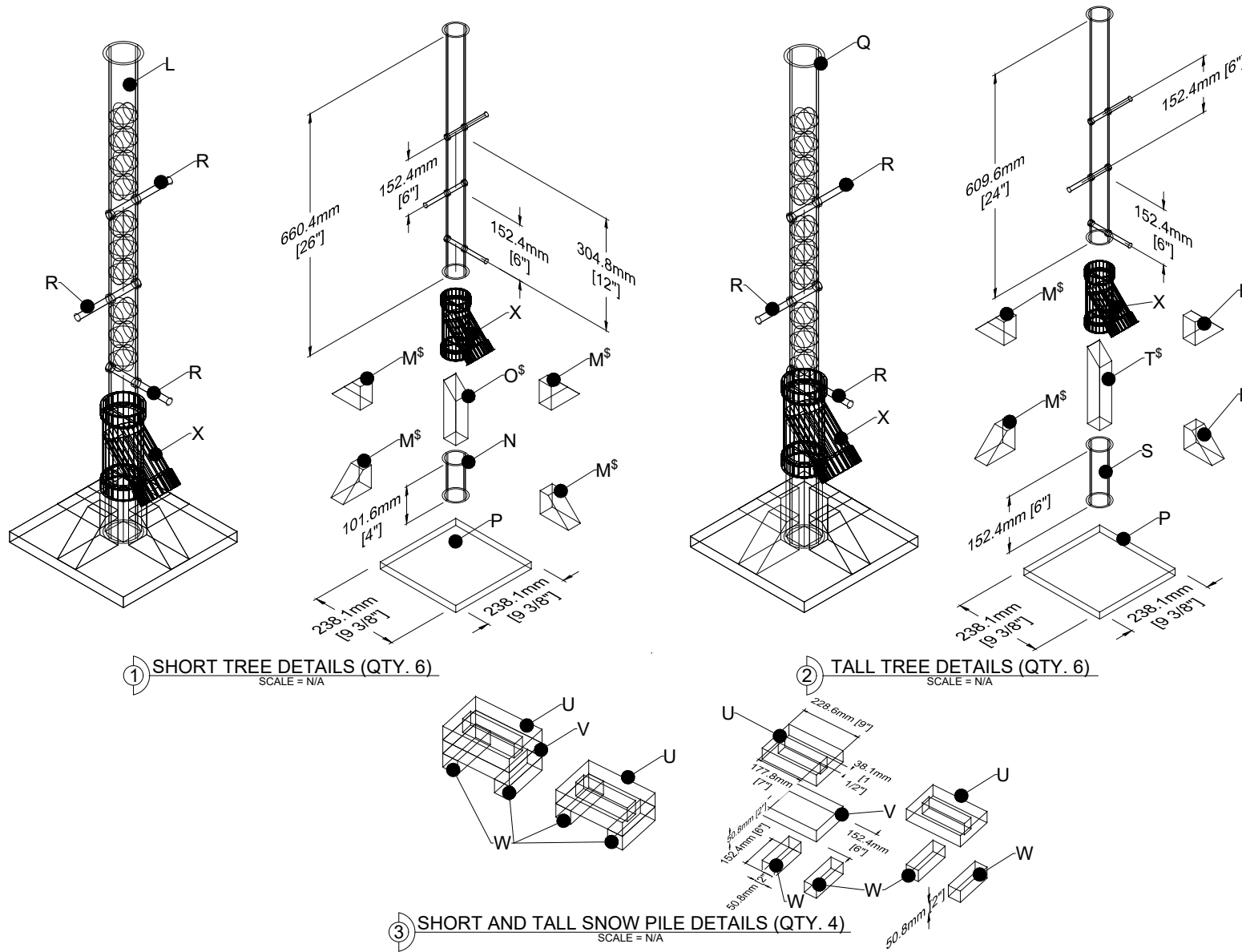

NOTES:

1. ALL MATERIALS LISTED ON ALL DRAWINGS REPRESENT INFORMATION AND DIMENSIONS FOR A FULL COURT AREA CONSISTING OF 2 TEAM COURT AREAS.
2. TEAM COURT AREAS ARE MIRRORED ALONG THE MIDDLE AXIS. DIMENSIONS ARE ALSO MIRRORED.

KEYNOTES:

\$ NOTED PIECES TO BE ANGLE CUT. SEE DIMENSIONS SHEET FOR DETAILS

-	-	-	-
0	ISSUED FOR SCOPE DOCUMENT	SM	JUL. 31/23
REV:	DESCRIPTION:	BY:	DATE:

REVISIONS

PROJECT: SCNC QUEBEC CITY 2024 - ROBOTICS	SCNC_RC_2024_4 DRAWING NO.	T2024 PROJECT NO.	07/31/23 DATE.
DRAWING TITLE: PART LABELLING (2 OF 2)	AS NOTED SCALE AT A4.	SM DRAWN.	DD CHECKED.
			0 REVISION.

SKILLS CANADA
 294 Albert Street, Suite 201
 Ottawa, Ontario
 1 (877) 754-5226



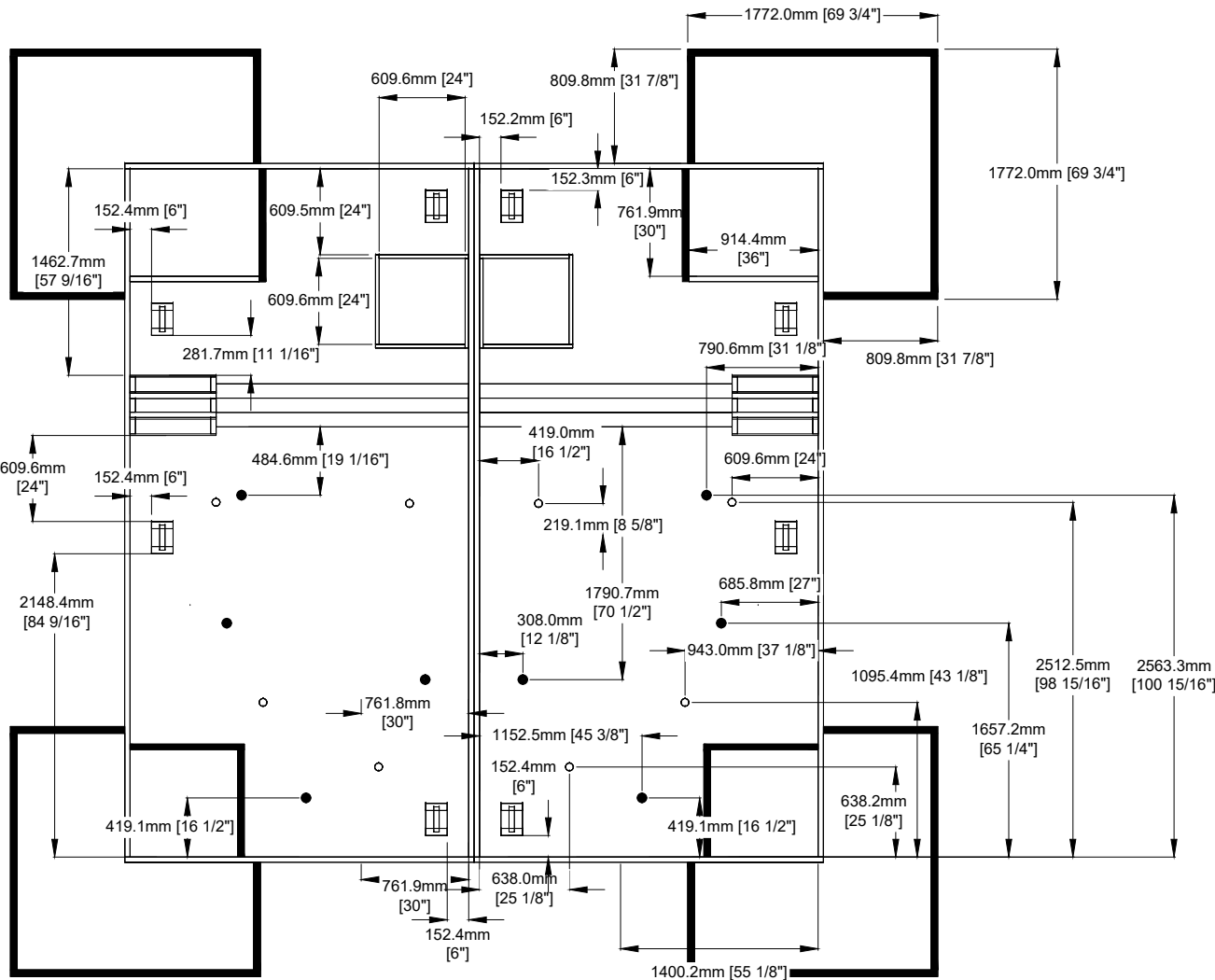

1 MAIN COURT DIMENSIONS
 (ROUND ROBIN AND TOURNAMENT LAYOUTS)
 SCALE = 1:50 (ON 8.5" x 11" PAPER)



NOTES:

1. ALL MATERIALS LISTED ON ALL DRAWINGS REPRESENT INFORMATION AND DIMENSIONS FOR A FULL COURT AREA CONSISTING OF 2 TEAM COURT AREAS.
2. TEAM COURT AREAS ARE MIRRORED ALONG THE MIDDLE AXIS. DIMENSIONS ARE ALSO MIRRORED.
3. SEE OVERALL COURT AREA DRAWING FOR SPECIFIC TREE DIMENSION PLACEMENTS DEPENDING ON GAME TYPE.

REV:	DESCRIPTION:	BY:	DATE:
-	-	-	-
0	ISSUED FOR SCOPE DOCUMENT	SM	JUL. 31/23

REVISIONS

PROJECT: **SCNC QUEBEC CITY 2024 - ROBOTICS** SCNC_RC_2024_5 T2024 07/31/23

DRAWING TITLE: **COURT DIMENSIONS** AS NOTED SM DD 0

SCALE AT A4. DRAWN. CHECKED. REVISION.



SKILLS CANADA
 294 Albert Street, Suite 201
 Ottawa, Ontario
 1 (877) 754-5226

NOTES:

1. ALL MATERIALS LISTED ON ALL DRAWINGS REPRESENT INFORMATION AND DIMENSIONS FOR A FULL COURT AREA CONSISTING OF 2 TEAM COURT AREAS.

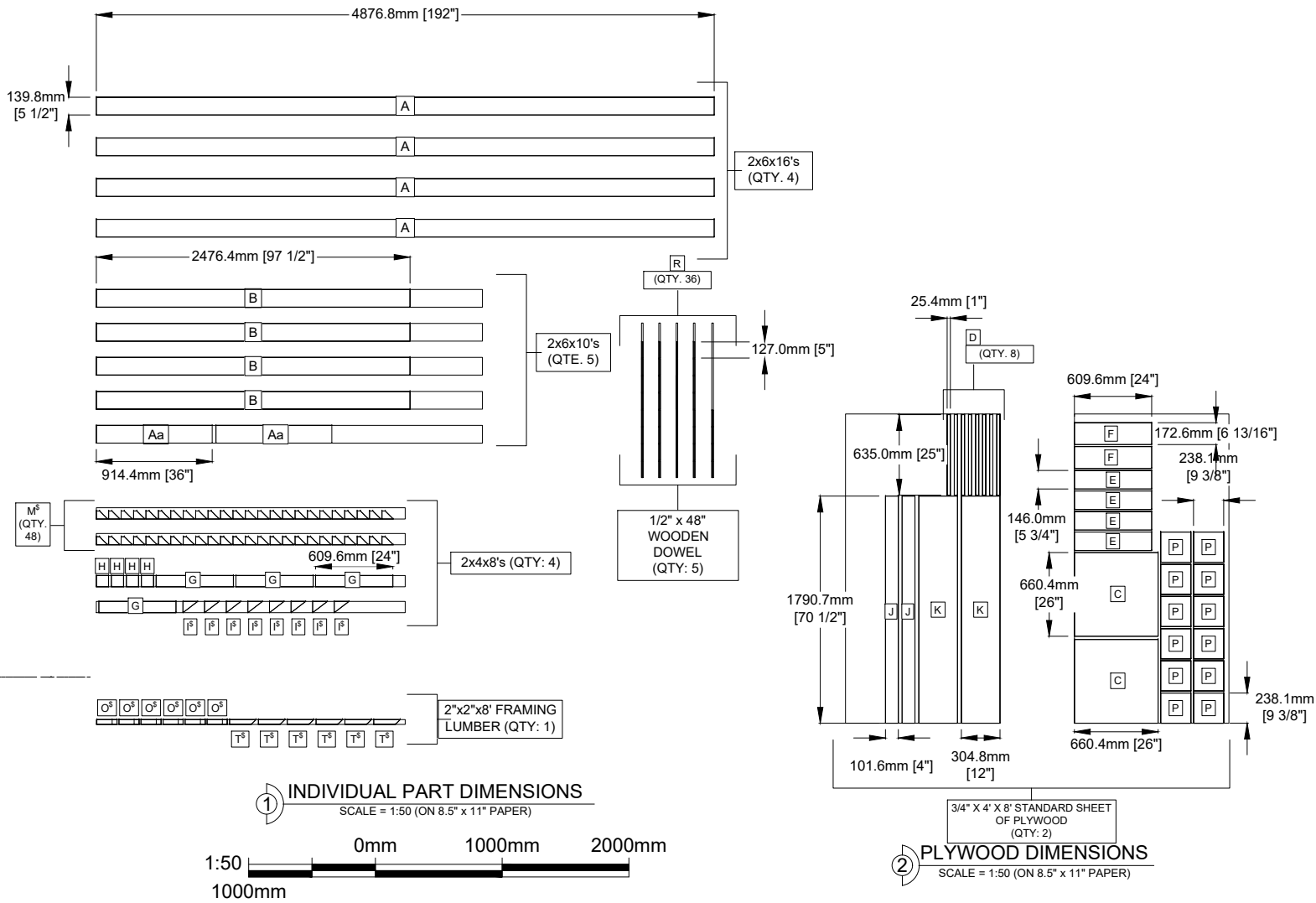

-	-	-	-
-	-	-	-
0	ISSUED FOR SCOPE DOCUMENT	SM	JUL. 31/23
REV:	DESCRIPTION:	BY:	DATE:
REVISIONS			

PROJECT: SCNC QUEBEC CITY 2024 - ROBOTICS	SCNC_RC_2024_6 DRAWING NO.	T2024 PROJECT NO.	07/31/23 DATE.	SKILLS CANADA 294 Albert Street, Suite 201 Ottawa, Ontario 1 (877) 754-5226
DRAWING TITLE: PART DIMENSIONS (1 OF 2)	AS NOTED SCALE AT A4.	SM DRAWN.	DD CHECKED.	

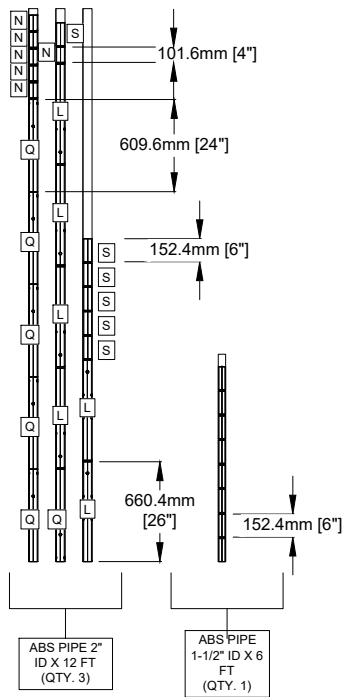

1 PIPE DETAILS
SCALE = 1:50 (ON 8.5" x 11" PAPER)

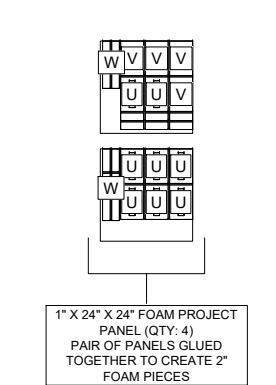

2 FOAM DETAILS
SCALE = 1:50 (ON 8.5" x 11" PAPER)

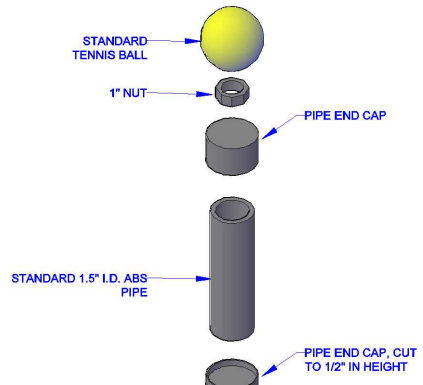

3 POLE DETAILS
SCALE = N/A

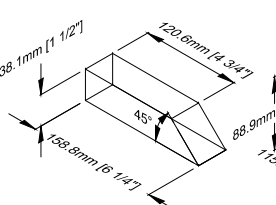

4 O DIMENSIONS
SCALE = N/A

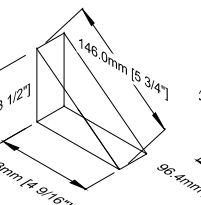

5 I DIMENSIONS
SCALE = N/A

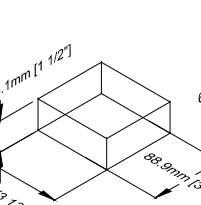

6 H DIMENSIONS
SCALE = N/A

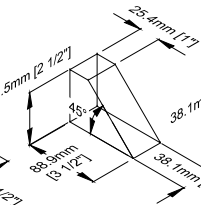

7 M DIMENSIONS
SCALE = N/A

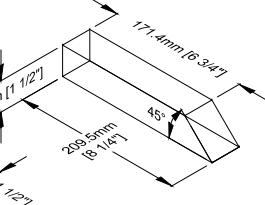

8 T DIMENSIONS
SCALE = N/A

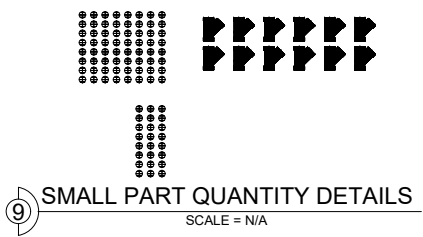

9 SMALL PART QUANTITY DETAILS
SCALE = N/A

NOTES:

1. ALL MATERIALS LISTED ON ALL DRAWINGS REPRESENT INFORMATION AND DIMENSIONS FOR A FULL COURT AREA CONSISTING OF 2 TEAM COURT AREAS.
2. TEAM COURT AREAS ARE MIRRORED ALONG THE MIDDLE AXIS.
3. SEE OVERALL COURT AREA DRAWING FOR SPECIFIC TREE DIMENSION PLACEMENTS DEPENDING ON GAME TYPE.

REV:	DESCRIPTION:	BY:	DATE:
0	ISSUED FOR SCOPE DOCUMENT	SM	JUL 31/23

REVISIONS

PROJECT:	SCNC QUEBEC CITY 2024 - ROBOTICS	DRAWING NO.:	SCNC_RC_2024_7	PROJECT NO.:	T2024	DATE:	07/31/23	SKILLS CANADA 294 Albert Street, Suite 201 Ottawa, Ontario 1 (877) 754-5226
DRAWING TITLE:	PART DIMENSIONS (2 OF 2)	AS NOTED	SM	DD	0	REVISION:		

NOTES:

1. ALL MATERIALS LISTED ON ALL DRAWINGS REPRESENT INFORMATION AND DIMENSIONS FOR A FULL COURT AREA CONSISTING OF 2 TEAM COURT AREAS.

<u>Description</u>	<u>Web Url</u>	<u>Quantity</u>
2" x 6" x 16' Standard SPF Dimension Lumber	https://shorturl.at/lpr46	4
2" x 6" x 10' Standard SPF Dimension Lumber	https://shorturl.at/ctATV	5
2" x 4" x 8' Standard SPF Dimension Lumber	https://shorturl.at/suK67	4
2" x 2" x 8' Framing Lumber	https://shorturl.at/gHJOX	1
1/2" x 48" Round Wooden Dowel	https://tinyurl.com/wdwwel	5
3/4" x 4' x 8' Standard Sheet of Plywood	https://tinyurl.com/5n7bkrrn	2
2" x 12' Cell Core ABS Pipe	https://tinyurl.com/12ftABSSC	3
1-1/2" x 6' Cell Core ABS Pipe	https://tinyurl.com/732rn4d	1
1" x 24" x 24" Foam Project Panel	https://tinyurl.com/433fx3kj	1
2" ABS 45 Degree Wye H x H x H	https://tinyurl.com/563fuzxs	12
1-1/2" ABS Slip On Test Cap	https://tinyurl.com/2m9bneuw	24
Steel Hex Nut, Zinc Plated Finish, Grade 5, 1" - 8 Threads	https://tinyurl.com/42vyam3v	2
Tennis Balls + 1 Extra Set	https://tinyurl.com/ymewejta	5
Foam Balls (qty. 12 in each pack)	https://tinyurl.com/2mmcn6t8	10
Red Foam Balls	https://tinyurl.com/redgolfball	3

1 BILL OF MATERIALS
SCALE = N/A

-	-	-	-
-	-	-	-
0	ISSUED FOR SCOPE DOCUMENT	SM	JUL. 31/23
REV:	DESCRIPTION:	BY:	DATE:

REVISIONS

PROJECT: SCNC QUEBEC CITY 2024 - ROBOTICS	SCNC_RC_2024_8 DRAWING NO.	T2024 PROJECT NO.	07/31/23 DATE.
DRAWING TITLE: BILL OF MATERIALS	AS NOTED SCALE AT A4.	SM DRAWN.	DD CHECKED.
			0 REVISION.



SKILLS CANADA
294 Albert Street, Suite 201
Ottawa, Ontario
1 (877) 754-5226